

## EBV

## Double Eccentric Butterfly Valve



- ♦ Robust & Compact design
- ♦ Blow-out shaft design as standard for increased safety
- ♦ Lip-seal design compensates temperature and pressure changes
- ♦ Tight shut-off in both directions
- ♦ No contact between seat and disc at open or intermediate positions
- ♦ Longer service life with less maintenance
- ♦ Reduced torque requirements, allowing smaller actuators

EBV, m-tech high performance butterfly valve, is focused on general purpose applications in oil and gas pipelines, chemical and petrochemical, energy and power, pulp and paper, HVAC. The selected standard configuration covers a wide range of applications, allowing shortest delivery time, even for complete valve packages.

### Technical data

♦ closing pressure ( $\Delta P$ )	16 bar
♦ Process connections:	Between flanges ANSI B16.5 Class150 and DIN EN1092-1 PN16
♦ Face to face:	API 609 cat.B / EN 558 Series 20 / ISO 5752 Series 20
♦ Nominal diameter	DN50 to DN300 (2" to 12")
♦ Body and disc Material	Stainless steel
♦ Seat seal	RPTFE
♦ Temperature range	-20°C to +200°C
♦ Leak rate	EN 12266 (Leakage rate A)
♦ Standards	Design and Manufacture: API 609 Pressure and Temperature: ASME B16.34 Inspection and Testing: API 598, DIN EN 12266-1

Version Oktober 2018

### Material specifications and exploded drawing

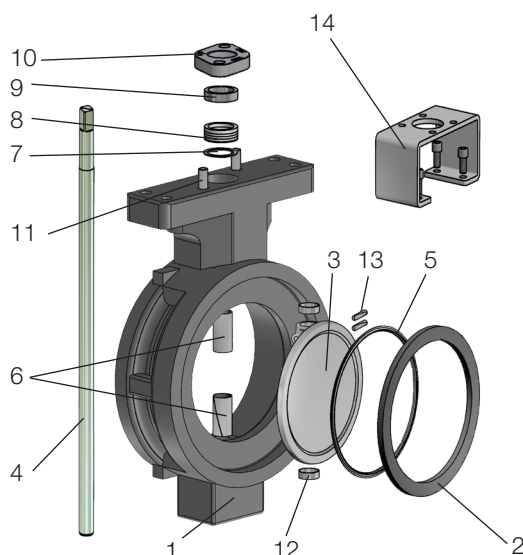

Position	Description	Material
1	Body	Stainless steel CF8M
2	Seat retainer	Stainless steel 316
3	Disc	Stainless steel CF3M
4	Stem	Stainless steel 17-4PH
5	Seat	R-PTFE
6	Stem bushing	Stainless steel 316+PTFE
7	Spacer	Stainless steel 316
8	Gland packing	Graphite
9	Retaining ring	Stainless steel 316
10	Gland retainer	Stainless steel CF8
11	Stud	Stainless steel
12	Thrust bushing	Stainless steel 316
13	Pin	Stainless steel
14	Mounting bracket	Stainless steel

# Dimensions

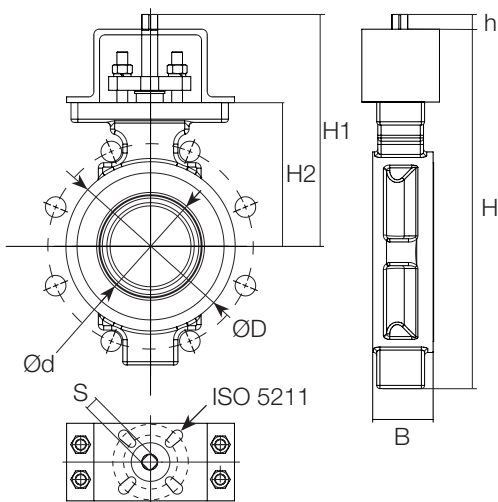

Valve Size	Ød	ØD	B	H	H1	H2	S	h	ISO 5211	Weight
DN50 (2")	38	100	43	221	125	80	9	14	F05/F07	3,65 kg
DN65 (2½")	59	118	48	275	194	111	11	14	F05/F07	5,45 kg
DN80 (3")	73	132	48	316	203	121	11	14	F05/F07	5,95 kg
DN100 (4")	95	157	54	341	217	133	11	14	F05/F07	7,80 kg
DN125 (5")	111	186	54	362	217	135	11	17	F05/F07	9,60 kg
DN150 (6")	142	217	57	384	235	152	14	17	F07/F10	12,90 kg
DN200 (8")	188	274	64	464	270	187	17	22	F07/F10	20,35 kg
DN250 (10")	236	330	71	560	325	232	22	27	F12/F14	31,50 kg
DN300 (12")	282	386	81	632	359	260	27	27	F12/F14	44,35 kg

Dimensions in mm

# Flow coefficient (Kv, Cv) - Torques

Valve Size	Kv (m³/h)		Cv (gal/min)		Max Torque (Nm)
	60°	90° (100%)	60°	90° (100%)	
DN50 (2")	23	47	27	55	30
DN65 (2½")	34	67	39	78	35
DN80 (3")	71	142	82,5	165	45
DN100 (4")	172	344	200	400	60
DN125 (5")	280	559	325	650	85
DN150 (6")	452	903	525	1050	120
DN200 (8")	946	1892	1100	2200	210
DN250 (10")	1419	2838	1650	3300	280
DN300 (12")	2193	4386	2550	5100	370

# Options with this valve type

- ♦ Manual gear box
- ♦ Pneumatic actuator Normally Close, Normally Open or Double Acting. Electrical actuator
- ♦ Pilot valve. Position feedback. Positioner
- ♦ Valve complete assembly with test certificates, engineering drawings and tag numbers
- ♦ Other options and materials on request

# Ordering code system

